

Smart OBD Car Tracker

Quick Start Guide

(Version 1.0)



To ensure quickly and correctly use, please read this manual carefully before using.
Any changes to the product appearance, color or accessories are without notice.

1. Functions

This product supports the most types of car since 2007. Please login in to the platform that specified by the dealers to ensure that the model of your car is in the supported OBD car type list. If your car does not support the OBD, then it can be used as a GPS tracker.

1.1 Functions



Current Position



Geo-fence



Remote Diagnostics



Fault Reminder



Vibration Alarm



Displacement Alarm



Track Playback

1.2 Parameters

- GSM850/900/1800/1900Mhz, Quad-band is in common use all over the world.
- GPRS: Class 12, TCP/IP
- Voltage: 9-36VDC
- Working current: ~9mA (12vDC)
- GPS Positioning time: Cold start -38s (open sky)
Warm start -32s
Hot start -2s (open sky)
- GPS positioning accuracy: 10m (2DRMS)
- Working condition temperature: -20°C---70°C
- Working condition humidity: 20%~80%
- Size: 86.6(L)*44.0(w)*13.6(H) mm
- Weight: 50.5g

2. Appearance and installation instructions

2.1 Appearance

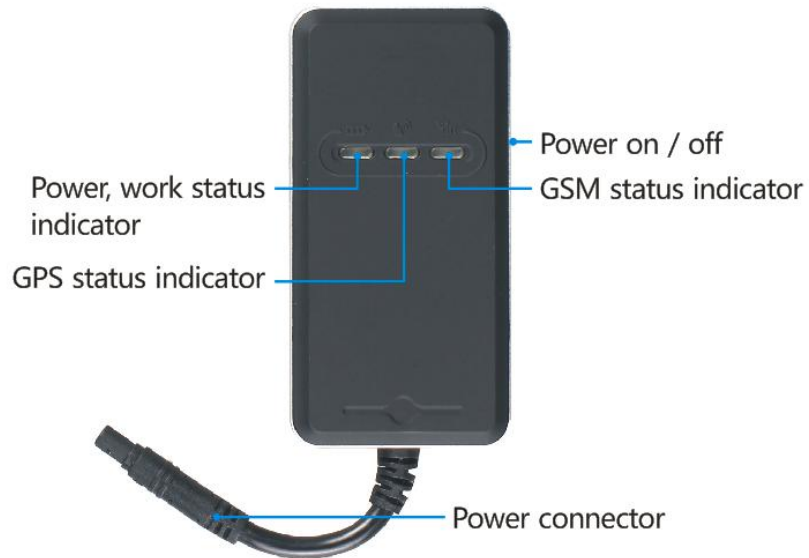

GPS tracker



OBD Diagnostic Instrument

3. Power on/off and installation guide

3.1 Power on and installation

① Push the cover downward

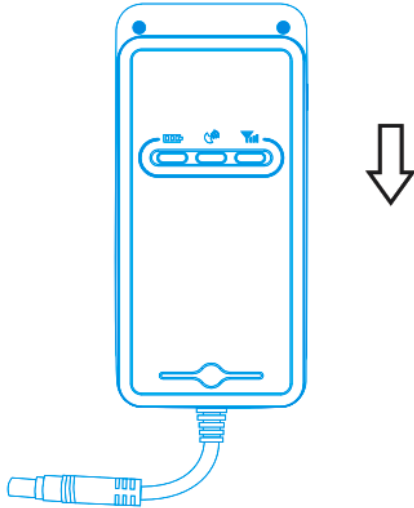

② Push the sim card buckle to the right

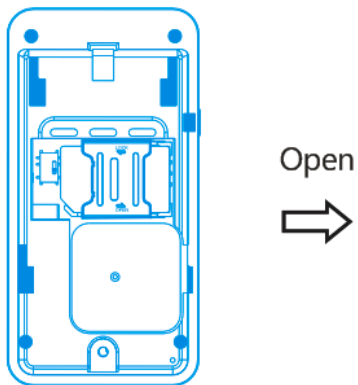

③ Open a sim card buckle upward

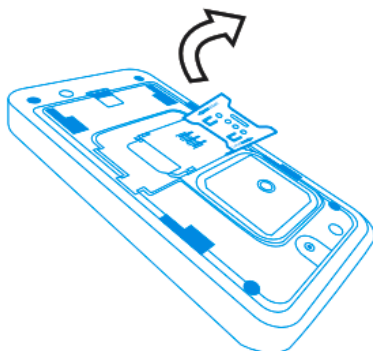

Note: SIM card needs to enable the GPRS function.

- ④ Please push the battery switch ON

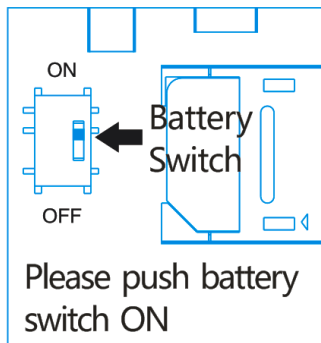

- ⑤ Push the cover upward

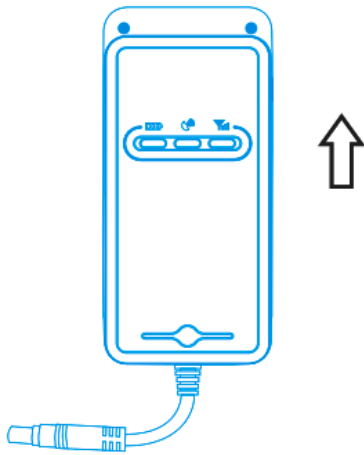

- ⑥ OBD Diagnostic Instrument connected with GPS tracker (note: pay attention to the direction of the connector)

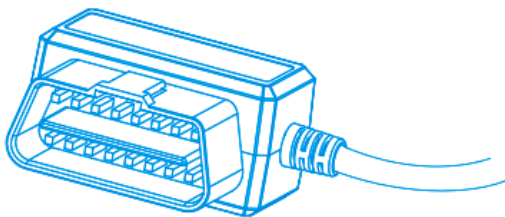

- ⑦ Find out the OBD interface (usually at the bottom of the steering wheel)

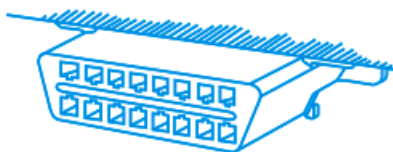

- ⑧ Insert OBD Diagnostic Instrument into vehicle OBD interface in the case that vehicle is engine off

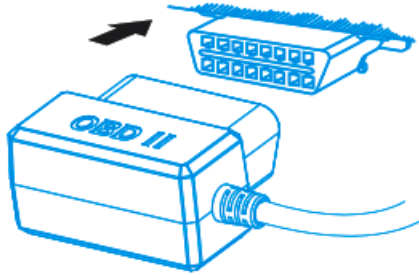

3.2 Power off

- ① Pull out the OBD Diagnostic Instrument

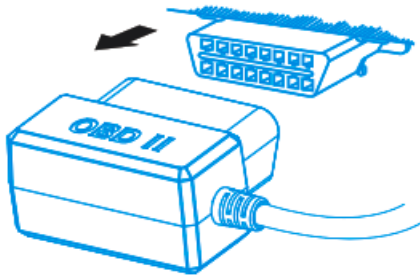

- ② Pull the cover downward

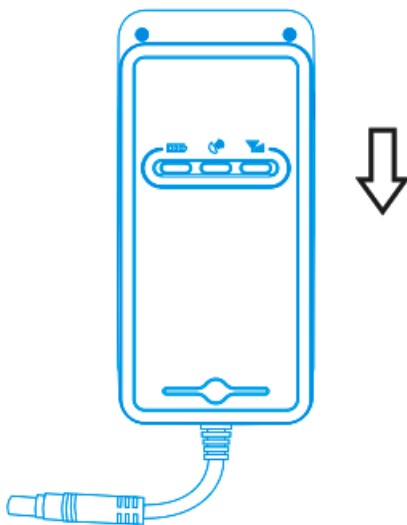

- ③ Turn the battery switch OFF and pull out the OBD Diagnostic Instrument.

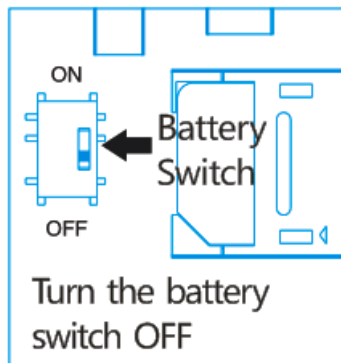

4. Installation

4.1 GPS tracker installation instructions

It's better to choose the dealers specified professional department or professions to install and test because this GPS tracker is a high-tech fleet management product.

Installation position

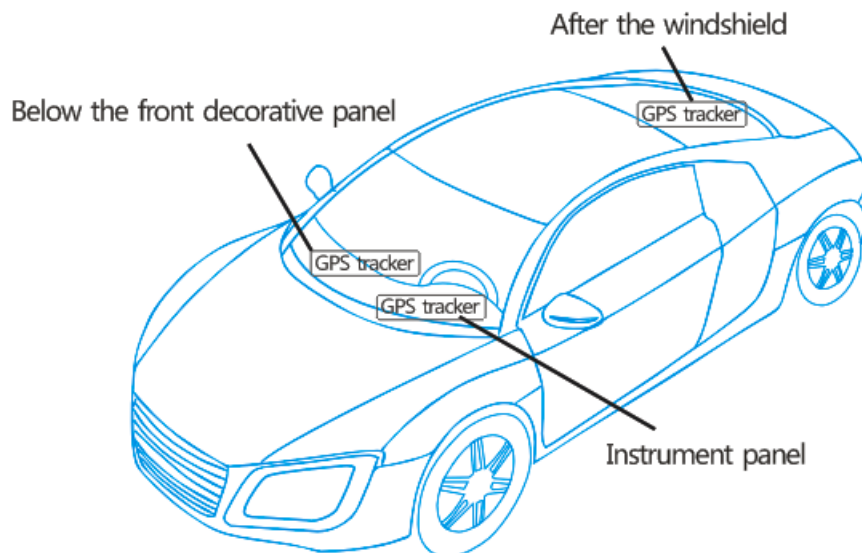

Note:

1. Please install the device upwards.

2. If the windshield has been pasted by lagging and heating, it will reduce GPS signals and resulting in abnormal GPS work, so please change GPS tracker installation position.

5. LED indicators definition

5.1 GPS tracker LED working status (non-dormant state)

5.1.1 Red LED (power/working status)

Status	definition
Sparkling	low battery
Light	charging
Flash	full/normal
Dark	low battery/ Internal error

5.1.2 Blue LED (GPS signal status)

Status	definition
Sparkling	searching
Light	receiving
Dark	out of work

5.1.3 Green LED (GSM signal status)

Status	definition
Sparkling	GSM initialing
Light	GSM receiving
Flash	GPRS connecting
Dark	Unconnected/without SIM card

5.2 Arm status indicators

Blue, red, green LED lights flashing circular signify that arm status is started.

6. Devices application operation

6.1 Login to supplier specified online tracking platform to set up and operation

6.2 Please login to the dealers specified website to download APP to install.



7. Appendix

7.1 Battery safety

- Please use battery that the original factory specified and use any other accessories will void the warranty. If use others accessories leading the GPS tracker damaged, we won' t assume any warranty responsibility.
- Please avoid the metal objects leads the battery contactors short-circuit.
- Please do not bend or forced open the battery.
- Please do not immerse the battery in water or on the fire. Batteries have to be recharged at closed room temperature. If the temperature is below 0°C or 45°C , the battery won' t to be charged.
- It' s forbid to use the battery that have deformation appearance, off-color, leakage or damaged complete package.

7.2 Troubleshooting

If find anything that is abnormal during the operation, please refer to the following problems and solutions. If the problem still can' t be solved, please contact the dealers or service provider.

FAQ	Problem	solution
Poor signal	The signal waves unable to transmit when use the GPS tracker in the places that have poor signal reception, such as: tall building around or basement.	Using the GPS tracker in the places that have good signal condition.
Unable to boot	Low battery	Insert the GPS tracker into the vehicle OBD interface to charge.
Unable to connect to the network	SIM card was not installed correctly.	Check the SIM card
	There is a dirty substance on the metal surface of the SIM card	Wipe the substance with a clean cloth
	SIM card is invalid	Please contact your network operator
	Beyond the GSM service area	Please move to the network service area
Unable to find out the location information	SIM card wasn' t open the GPRS service	Please contact your network operator to open the GPRS service.
	Always reply" unable to find the data, please try again"	Please contact your network operator
No diagnostic data	Vehicle is not suitable for testing	Please ensure your car is supports to use the OBD device before buying it
	GPRS data is not enough	Recharge

ShenZhen Concox Information Technology CO.,Ltd

Tel: +86 755 2912 1200

Fax: +86 755 2912 1290

E-mail: jason@concox.cn

Add: 4/F, Building B, Gaoxinqi Industrial Park,

Liuxian 1st Road, No.67 Bao'an District, Shenzhen

www.iconcox.com