

FIFOTRACK VEHICLE GPS TRACKER

4 RS232 PORTS

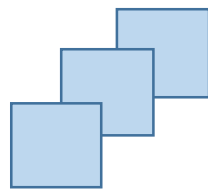
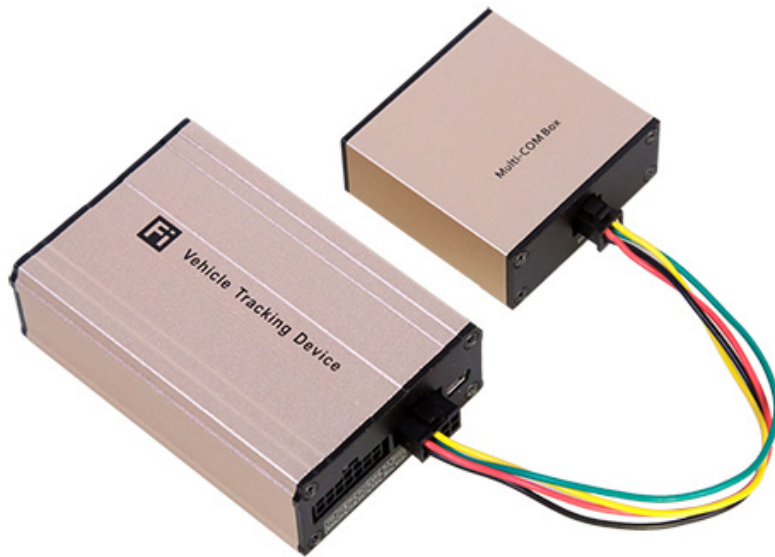

Model: A600

Version: V1.1

www.fifotrack.com

Copyright and Disclaimer

- ⦿ All copyrights belong to Shenzhen fifotrack Solution Co., Ltd. You are not allowed to revise, copy or spread this file in any form without consent of fifotrack.
- ⦿  is trademark of fifotrack, protected by law.
- ⦿ Please read this user guide carefully before installation to avoid any possible personal injury or property loss.

Revision History

Version	Author	Revision Date	Description of change
V1.1	Cici Wu	June 28, 2017	Initial revision

Related Files

Version	File	Remarks
V1.2	<fifotrack A600 Command List>	GPRS/SMS/COM command details of A600
V1.1	<fifotrack Parameter Tool User Guide>	PC software tool for parameters configuration
V1.1	<USB Cable Driver Installation Guide>	How to install USB cable driver
V1.1	<Firmware Upgrade Guide>	How to upgrade firmware
V1.2	< fifotrack RFID Reader User Guide>	How to use RFID Reader
V1.1	< fifotrack iButton User Guide>	How to use iButton
V1.1	< fifotrack Digital Temperature Sensor User Guide>	How to use digital temperature sensor
V1.1	< fifotrack Camera User Guide>	How to use camera
V1.1	< fifotrack Ultrasonic Fuel Sensor User Guide>	How to use ultrasonic fuel sensor
V1.1	<fifotrack Fingerprint User Guide>	How to use fingerprint scanner
V1.1	<fifotrack Vehicle Original Fuel Sensor Solution User Guide>	How to find out Original fuel sensor cable and use it.
Download link: http://www.fifotrack.com/Support/Userguide/ Video Support: http://www.fifotrack.com/Support/video.html		

Related Software

Version	Software	Remarks
V1.0	< Parameter Tool >	Parameter configuration tool on PC
V1.11.0	< PL2303_Prolific_DriverInstaller >	Driver for USB cable
V1.0	< Firmware Upgrade Suite>	Tool for firmware upgrade
Download link: http://www.fifotrack.com/Support/Userguide/		

Contents

1 Product Overview	6
2 Product Functions	6
2.1 Tracking Functions	6
2.2 Alarms	6
2.3 Other Functions	7
3 Product and Accessories	8
3.1 Standard Packing Box.....	8
3.2 Optional Accessories.....	8
4 Product Appearance	9
5 PCB Overview and Hardware Design.....	10
5.1 Hardware Design Highlight	10
6 LED Light	11
7 Specification	11
8 First Use	12
8.1 Charging.....	12
8.2 Installing the SIM Card.....	12
8.3 Installing GSM/GPS Antenna	13
8.4 Tracking by Calling	13
8.5 SMS Reply Content Example	14
8.6 Tracking by SMS Command - C01	15
8.7 Configuration by PC	16
8.8 Platform Tracking	16
9 Device Installation.....	17
9.1 I/O Installation	17
9.2 Multi-COM Box	18
9.3 Power/Ground Cable	19
9.4 Positive/Negative Digital Input (IN1/IN2/IN3)	19
9.5 Analog Input (AD)	20
9.6 Output control (OUT1/OUT2).....	20

1 Product Overview

A600 is an advanced model which is suitable for fleet management, public transportation management, school bus management, taxi operation management, vehicle insurance company management, rent car management and private car antitheft, etc. A600 supports 4 RS232 ports and 1-Wire protocol, this enables A600 to have powerful functions such as taking pictures, driver identification and management, impulse detection and temperature monitoring.

Besides the advanced functions, A600 has full functions to cover the normal demands of vehicle tracking. Not only has fuel monitoring, harsh acceleration/braking alarm, driving behavior analysis, but also has custom digital input, jamming detection, two-way calling and OTA functions. A600 uses own FIFOTRACK GPRS PROTOCOL which is simple and practical, this enables the customers to integrate on their own platform efficiently.

2 Product Functions

2.1 Tracking Functions

- GPS+GSM Base Station Dual Tracking
- Real Time Tracking
- Time Interval Tracking
- Distance Tracking
- Direction Change Tracking
- Mobile Phone Tracking

2.2 Alarms

- SOS Alarm
- GPS Antenna Cut Alarm
- External Power Cut Alarm
- Engine/Door Status Alarm
- GEO-Fence Alarm
- Speeding Alarm
- Idling Alarm
- Fatigue Driving Alarm

- Harsh Acceleration Alarm
- Harsh Braking Alarm
- Parking Overtime Alarm
- Vibration Alarm
- GPS Jamming Alarm
- GSM Jamming Alarm
- Internal Battery Low Alarm
- External Battery Low Alarm
- Driver Login/log out Alarm
- High/Low Temperature Alarms
- Fuel Theft Alarm
- Fuel Filling Alarm
- Low Fuel Level Alarm
- High Fuel Level Alarm

2.3 Other Functions

- Stop Car Remotely
- 8 MB Flash Memory
- Custom Digital Input
- OTA
- Uploading Mode Settings for ACC ON/ACC OFF
- Roaming Time Interval Setting
- Mileage And Running Time Settings
- Accurate Fuel consumption statics
- Vehicle Original Fuel Sensor Supported
- Tacking Picture via Camera (Optional)
- Driver Identification and Management via RFID Reader, iButton or fingerprint (Optional)
- Fuel sensor Capacitive type or Ultrasonic Fuel Sensor (Optional)
- Temperature Sensor (Optional)
- Voice Monitoring (Optional)
- Two-way Calling (Optional)
- Impulse Detection (Default speedometer detection)
- 4 RS232 Port (1 RS485 is reserved, 1 RS232 can be modified to 1 RS485)

3 Product and Accessories

3.1 Standard Packing Box



A600 and Multi-COM Box



Wire



GPS Antenna



GSM Antenna

3.2 Optional Accessories



USB Cable



Relay



Microphone



Speaker



AS10 Fuel Sensor



Calibrator for AS10



RFID reader



Tag



Camera



iButton



TUB01 Ultrasonic fuel sensor



LED Tool for TUB01



Fingerprint



Temperature Sensor

4 Product Appearance

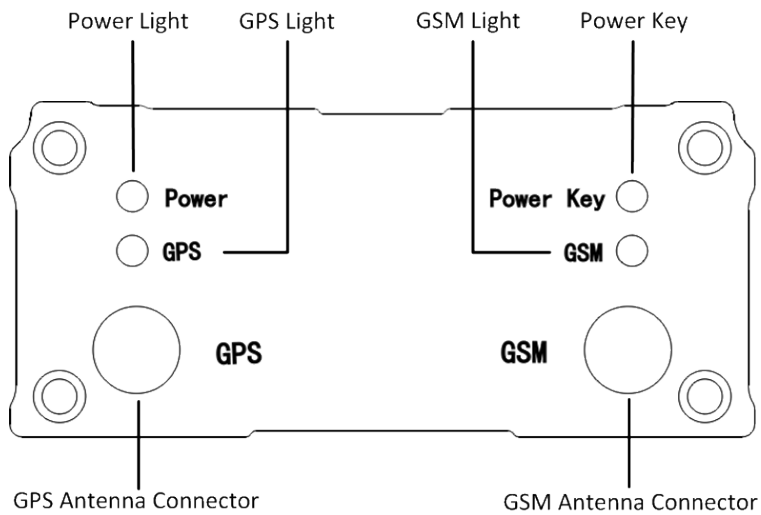
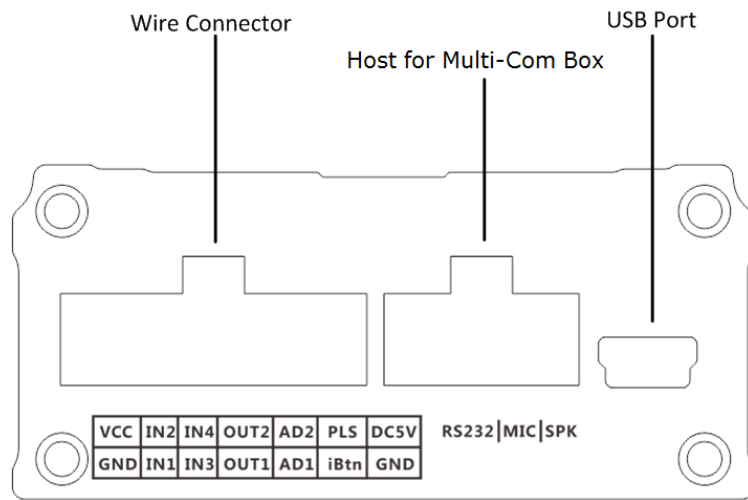

5 PCB Overview and Hardware Design

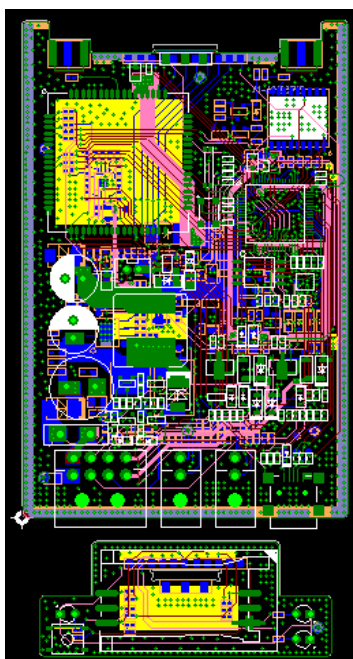

5.1 Hardware Design Highlight

Protection for sudden-change of auto power supply: When the vehicle starts or is running, the power voltage will have a wave of change. Our product supports voltage 11V-36V. When the external power supply is below 10.5V, with low voltage detection, it will be automatically cut. When external power supply is over 36V or has high voltage peak, the product will trigger high-voltage protection through clamping, anti-pulse, and high voltage detection. This ensures the product to operate normally under high voltage.

Auto power transient pulse: When the vehicle starts or is running, it will generate high-voltage transient pulse with a range of hundreds of volts. If the product's circuit is not well designed, it is very easy to get damaged, and can't be used. Through multistage transient pulse protection and anti high-voltage surge protection, the product's power circuit is well protected, and it can operate stably.

Electromagnetic immunity: When the vehicle starts, the clock, RF, display screen and USB are very easy to be interfered by electric spark, which causes the product to operate unstably. Through PCB layout and ground wire handling, the product can work stably under interfered environment.

Anti static: The vehicle product's working condition is complex. It is very easy to be influenced by static, which causes damage to the product's peripheral interfaces. Through ESD protection on

circuit and ground wire handling, the static in the range of 8KV-15KV won't cause damage to product. This ensures the product's stability under complex working condition.

6 LED Light

GPS Light (Green)	
Off	Power off or sleep
Flash 0.1s on and 3S off	GPS valid
Flash every 0.1s	GPS antenna cut
Flash 2s on and 2s off	No GPS signal
On	GPS module power problem
GSM Light (Orange)	
Off	Power off or sleep
Flash 0.1s on and 3s off	GSM available
Flash every 0.1s	Device is initialing
Flash 2s on and 2s off	No GSM
External Power Light (Red)	
Off	External power cut
Flash every 0.1s	External power low
On	External power normal

7 Specification

Item	Specification
Dimension	90*60*27mm
Weight	145g
GSM Module	SIMCOM800
GPS Module	U-blox7Q
Input Voltage	DC 11~36V/2A
Internal Battery	600mAh/3.7V
Power Consumption	30-35mA standby current
Internal Battery Life	15 hours in sleep mode, and 6 hours in normal working mode.
Operating Temperature	-20°C~70°C
Humidity	5%~95%
LED Light	3 LED lights indicating GPS/GSM/External power status
Button/ Switch	1 SOS Button, 1 power switch

Flash Memory	8MB (GPSR data 20400 units, SMS data 300 units)
Sensor	3D Accelerator Sensor
GSM Frequency Band	GSM 850/900/1800/1900MHz
GPS Sensitivity	-161dBm
GPS Start Speed	Cold start 35s Hot start 1s
Position Accuracy	10m
I/O Port	4 Digital inputs - 1 negative input, 1 positive input, 2 custom input (Default 1 positive input, 1 negative input) 2 Analog input AD1: 0~6V AD2: 0~12V 2 Output 4 RS232 port (camera/RFID reader/ultrasonic fuel sensor/fingerprint/two-way calling or other RS232 sensors) 1 RS485 port (reserved, 1 RS232 can be modified to 1 RS485) 1-Wire protocol (Temperature sensor/i-Button) 1 Impulse detection (Default speedometer detection) 1 USB port

8 First Use

8.1 Charging

First time use A600, please connect positive wire(+ Red) and ground wire(-black) to 12V or 24V external power supply, the charging current should be great than **2A**. Charging device at least 2 hours, 3 hours is suggested. Before installation, ensure all of the parameters setting and test are finished.

8.2 Installing the SIM Card

- Device can't support 3G or 4G network. Make sure the SIM card supports 2G.
- Ensure the SIM card has enough balance.
- Ensure PIN code has been closed.
- Authorization SOS numbers can't work well if SIM card doesn't have caller ID service. E.g.: device can't reply SMS to authorization SOS number because SIM card can't identify incoming call.

- SIM card should have GPRS function for platform tracking.
- Turn off device before SIM card installation.



Screw off and open the front cover



Insert SIM card into SIM card slot

Make sure the chip is facing to PCB.
Pay attention to the cutaway angle
direction of SIM card.



Close front cover and lock the screw

8.3 Installing GSM/GPS Antenna

Connect GSM Antenna to SMA connector with “GSM” silk. The GSM antenna’s signal is omnidirectional, you can hide it anywhere that is far from the power supply.

Connect GPS Antenna to SMA connector with “GPS” silk. GPS antenna should face to the sky for stronger GPS signal reception, and the silvery silk side should be downward. Fix GPS antenna with double sided tapes for stable signal reception.

 Don’t install the GPS antenna where shielded by metal. For example, inside a metal can.

8.4 Tracking by Calling

Call the SIM card number inside A600, you will get a SMS reply with Google map link. Click it for specific map location.

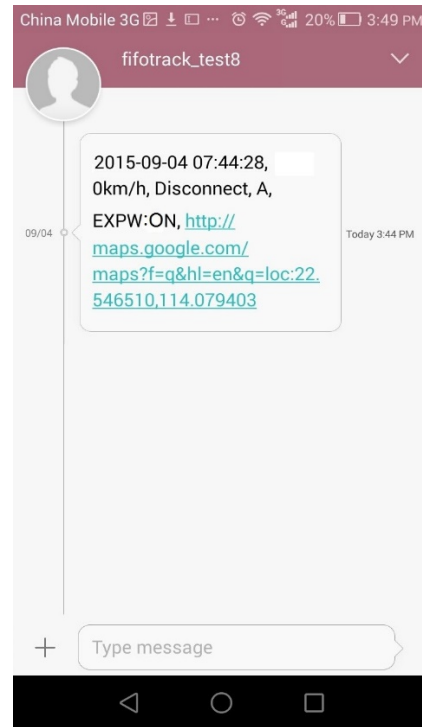
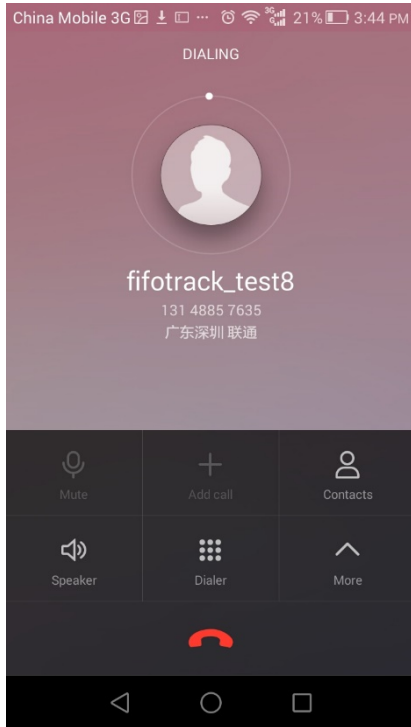

8.5 SMS Reply Content Example

2015-09-04 07:44:28, 0km/h, Disconnect, A, EXPW:ON,http://maps.google.com/maps?f=q&hl=en&q=loc:22.546510,114.079403

SMS Reply Format:

Field	Detail	Remarks
-------	--------	---------



2015-09-04 07:44:28	Date and time, format YYMMDD hh:mm:ss	Date and time
0Km/h	Speed is 0km/h	Speed
Disconnect	GPRS disconnect	GPRS connection status, "Disconnect" or "Connect".
A	GPS fixed	GPS Status, "A" means GPS valid, "V" means GPS invalid.
EXPW:ON	External power on	External power status. "ON" means external power normal, "OFF" means external power cut.
http://maps.google.com/maps?f=q&hl=en&q=loc:22.546510,114.079403	Google map link, latitude in the front of longitude after "Loc". Unit degree Latitude=22.546510° Longitude=114.079403°	Google map link with latitude and longitude, which can be opened directly on smart phone.

8.6 Tracking by SMS Command - C01

SMS Command: 000000,C01

SMS Reply: Current location

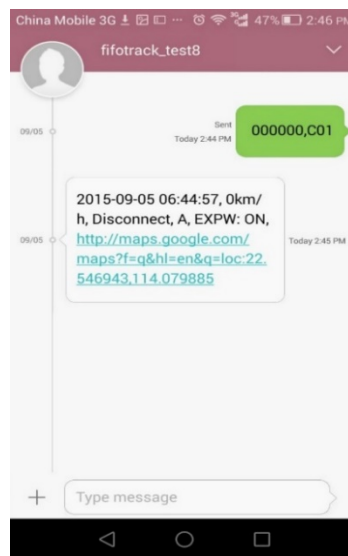

Note: Default SMS password is "000000", set new SMS password with B10 command.

Please refer to <FIFOTRACK COMMAND LIST> for more details.

8.7 Configuration by PC

fifotrack company provide <FIFOTRACK PARAMETER TOOL> for configuration. Please download USB cable driver and install it before using parameter tool. Refer to <USB CABLE DRIVER INSTALLATION GUIDE> if need.

Connect A600 to PC with USB cable. Run “Parameter Tool” software which will identify port automatically and read all of the current parameters.

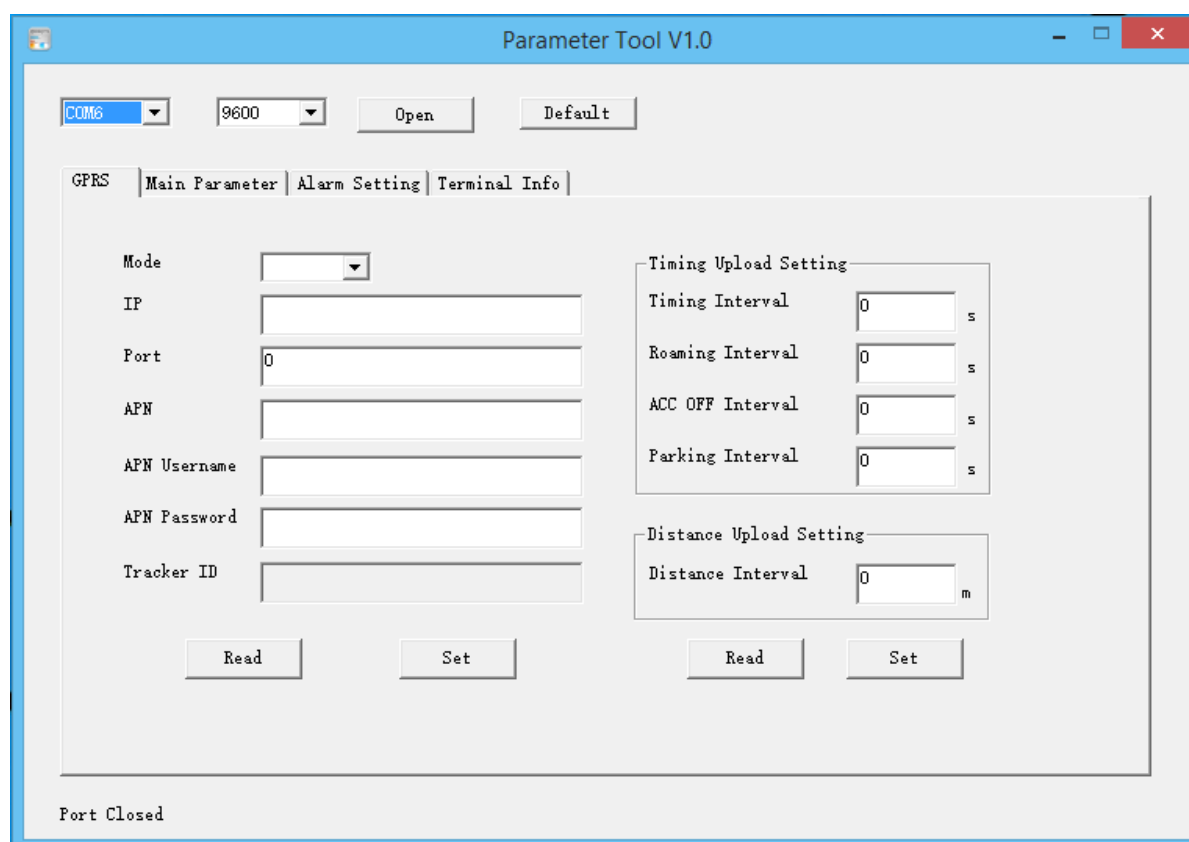

Please read <FIFOTRACK PARAMETER TOOL USER GUIDE> for more details.

8.8 Platform Tracking

You can use SMS commands B00, B01, B02, B03 to set server IP, port, APN and GPRS uploading interval.

You can also set those parameters via parameter tool software on PC.

9 Device Installation

9.1 I/O Installation

I/O wire has 14 pins, including power, digital positive and negative inputs, output, analog input, impulse detection and 1-Wire protocol cables.



VCC	IN2	IN3	OUT2	AD2	PLS	DC5V
GND	IN1	IN4	OUT1	AD1	iBtn	GND

I/O	Color	Function
VCC	Red	Positive power, connect to positive of vehicle battery, input voltage range 11-36V
GND	Black	Ground, connect to negative of vehicle battery or the vehicle's iron part.
IN1	White	Digital input1, negative input (default SOS button)
IN2	White	Digital input2, positive input, default connect to ACC for status detection.
IN3	White	Digital input3, custom input, default positive.
IN4	White	Digital input4, custom input, default negative.
OUT1	Yellow	Output1 Output active: low level (0V) Output inactive: open drain (OD) Max open-drain (inactive) voltage: 45V Max current for output low voltage (valid): 500mA

OUT2	Yellow	Output2 Output active: low level (0V) Output inactive: open drain (OD) Max open-drain (inactive) voltage: 45V Max current for output low voltage (valid): 500mA
AD1	Blue	12 bits analog input, supports voltage range 0-6V. Connect to external sensor, eg, fuel sensor.
AD2	Blue	12 bits analog input, supports voltage range 0-12V. Connect to external sensor, eg, fuel sensor.
PLS	Purple	Impulse detection, 0~100kHz
GND	Black	1-Wire protocol port for iButton or temperature sensor
DC5V	Orange	
iBtn	Brown	

RS232|MIC|SPK

Host port for Multi-Com Box	DC5V	MCU_RS232_TX	MIC+	SPK+
	GND	MCU_RS232_RX	MIC-	SPK-

9.2 Multi-COM Box



RS232 COM	I/O	Function
COM1	DC5V	RS232 port for camera/RFID Reader/ultrasonic fuel sensor/fingerprint or other RS232 protocol devices.
	GND	
	MCU_RS232_TX	
	MCU_RS232_RX	
COM2	DC5V	RS232 port for camera/RFID Reader/ultrasonic fuel sensor/fingerprint or other RS232 protocol devices.
	GND	

	MCU_RS232_TX	
	MCU_RS232_RX	
COM3	DC5V	RS232 port for camera/RFID Reader/ultrasonic fuel sensor/fingerprint or other RS232 protocol devices.
	GND	
	MCU_RS232_TX	
	MCU_RS232_RX	
COM4/RS485	DC5V	RS232 port for camera/RFID Reader/ultrasonic fuel sensor/fingerprint or other RS232 protocol devices.
	GND	
	MCU_RS232_TX	Reserved for RS485 port (It can be modified to 1 RS485)
	MCU_RS232_RX	

9.3 Power/Ground Cable

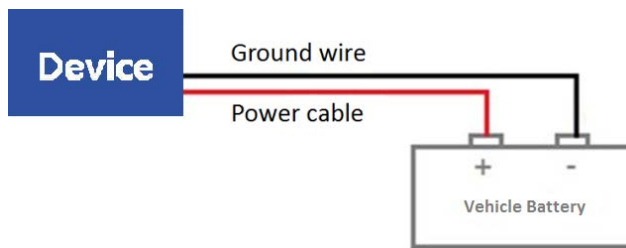

9.4 Positive/Negative Digital Input (IN1/IN2/IN3)

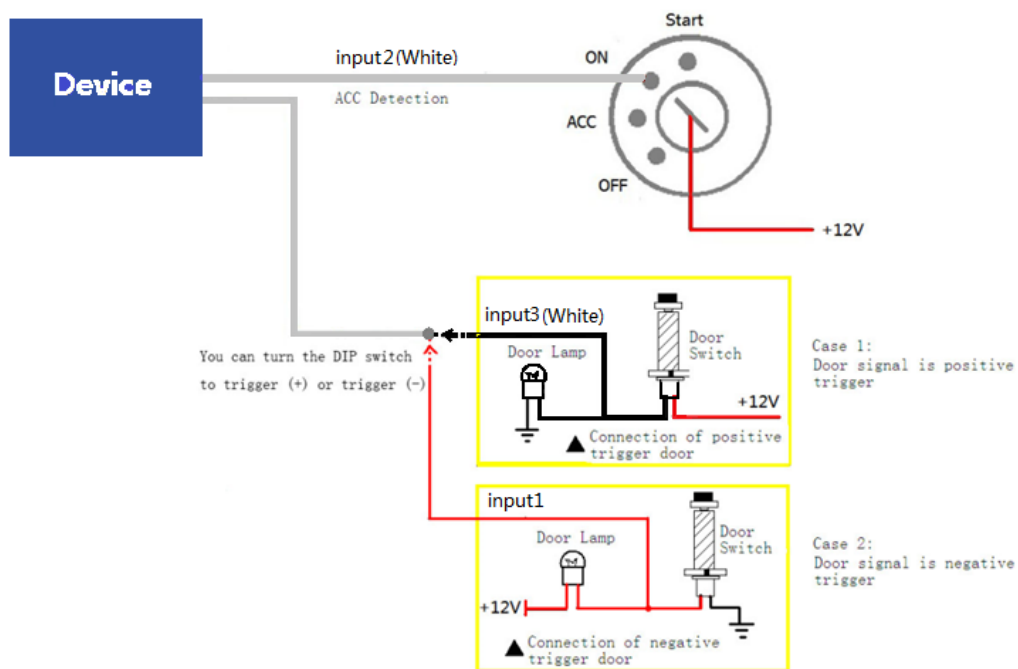

9.5 Analog Input (AD)

A600 supports 2 Analog input, whose voltage range:

AD1: 0~6V

AD2: 0~12V

Calculation formula:

AD1 Voltage=(AD1)*3300*2/4096

AD2 Voltage=(AD2)*3300*62/(4096*15)

Note: Original AD value is in hexadecimal. Convert it to decimal first, then use the formula.

9.6 Output control (OUT1/OUT2)

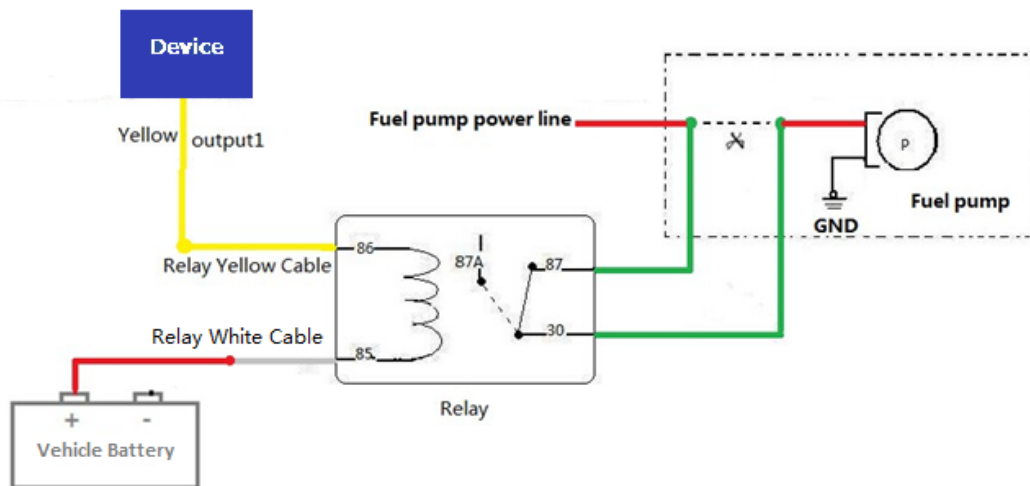

Please e-mail us at info@fifotrack.com if any question or feedback.